



250 Staunton Turnpike, Parkersburg, WV 26104

5400/5400S SERIES

Vinyl Horizontal Sliding Window

"NON-IMPACT"

GENERAL NOTES

1. This product has been evaluated and is in compliance with the 8th Edition (2023) Florida Building Code (FBC) structural requirements excluding the "High Velocity Hurricane Zone" (HVHZ).
2. Product anchors shall be as listed and spaced as shown on details. Anchor embedment to base material shall be beyond wall dressing or stucco.
3. When used in areas requiring wind borne debris protection this product is required to be protected with an impact resistant covering that complies with FBC Sections 1609.1.2 & R301.2.1.2.
4. For 2x stud framing construction, anchoring of these units shall be the same as that shown for 2x buck masonry construction.
5. Site conditions that deviate from the details of this drawing require further engineering analysis by a licensed engineer or registered architect.

TABLE OF CONTENTS	
SHEET#	DESCRIPTION
1	Typical elevations, design pressures and general notes
2	Horizontal cross sections
3	Vertical cross sections
4	Buck and frame anchoring
5	Components
6	Bill of materials & glazing detail

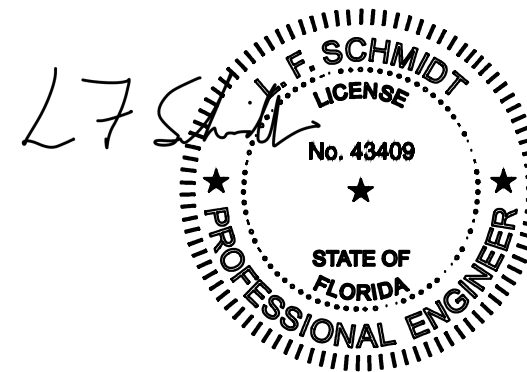

This item has been digitally signed and sealed by L. F. Schmidt, P.E. on the date adjacent to the seal. Printed copies of this document are not considered signed and sealed and the signature must be verified on any electronic copies.

THIS PRODUCT APPROVAL IS VALID ONLY FOR THE STATE OF FLORIDA

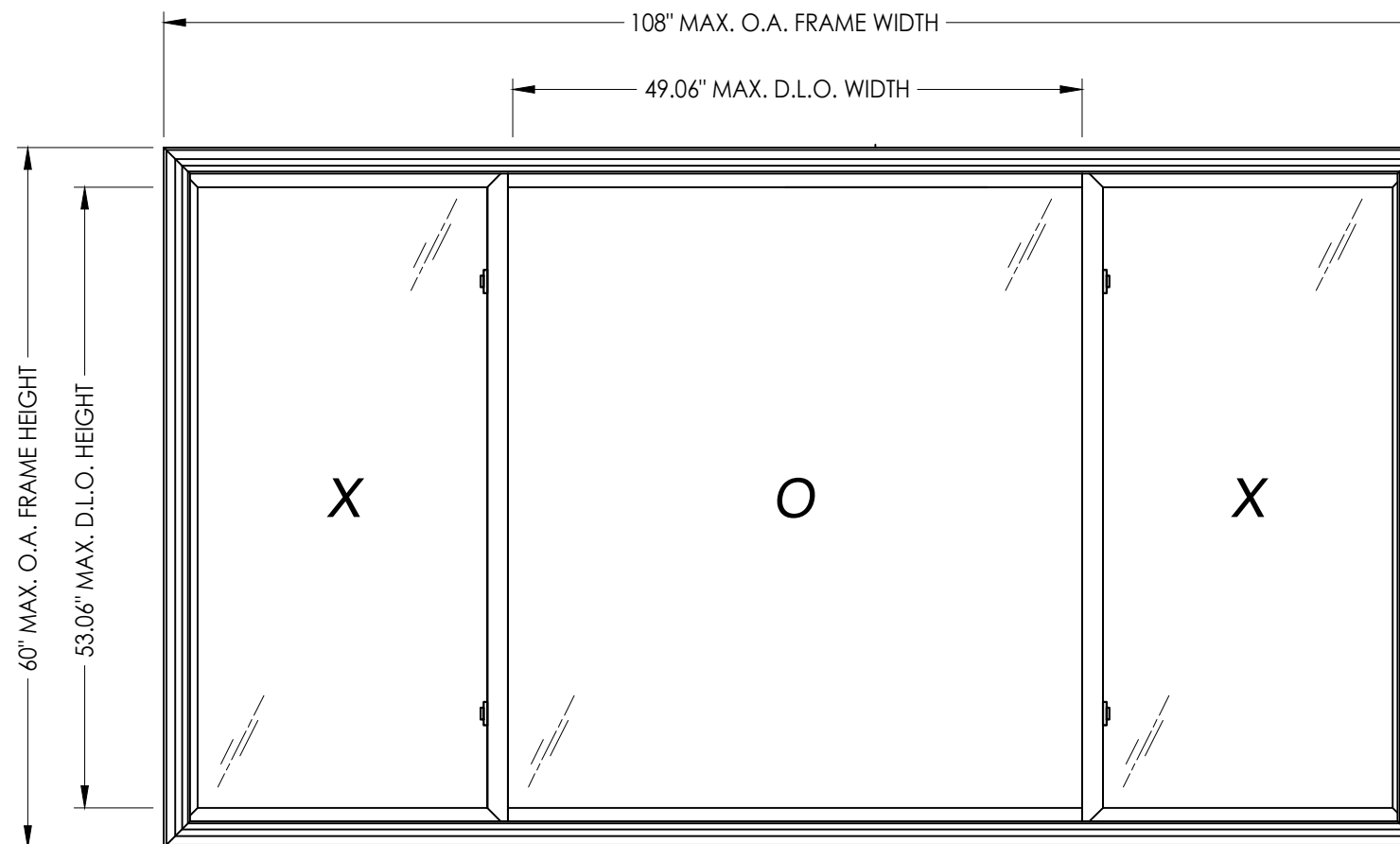

XOX SHOWN
XXX ALSO APPROVED

MAX. FRAME DIMENSION	MAX. D.L.O. DIMENSION	GLASS TYPE	DESIGN PRESSURE (PSF)	
			POSITIVE	NEGATIVE
108.0" X 60.0"	49.06" X 53.06"	G1	+20.0	-25.0
96.0" X 48.0"	43.06" X 41.06"	G1	+35.0	-45.0

Documents Prepared By:
Lyndon F. Schmidt
P.E. No. 43409

RW BUILDING CONSULTANTS, INC.
P.O. Box 230, Valrico, FL 33595
Phone No.: 813.659.9197
FBPE Registry No. 9813

PRODUCT: 5400/5400S SERIES
1/4-1/2-1/4

PART OR ASSEMBLY:
TYPICAL ELEVATION, DESIGN PRESSURES & GENERAL NOTES

NO.	DATE	BY
4	7/06/23	LFS
3	7/06/20	LFS
2	6/01/17	LFS
1	1/28/15	JK

REVISIONS

DATE: 10/4/13
SCALE: N.T.S.
DWG. BY: JK
CHK. BY: LFS
DRAWING NO.: FL-16092.19
SHEET 1 OF 6

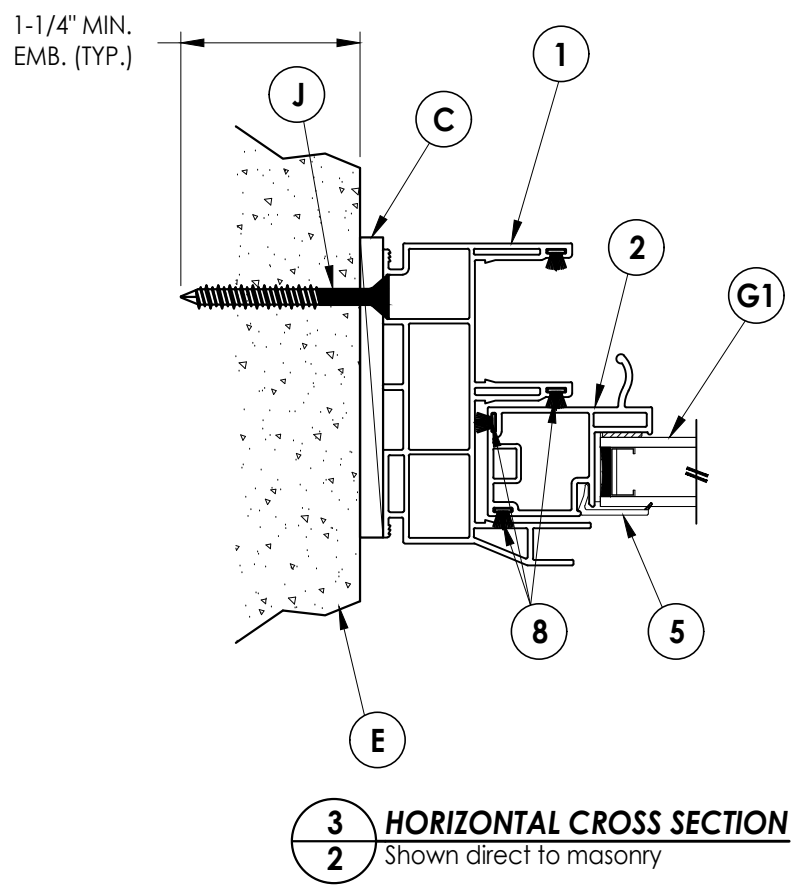
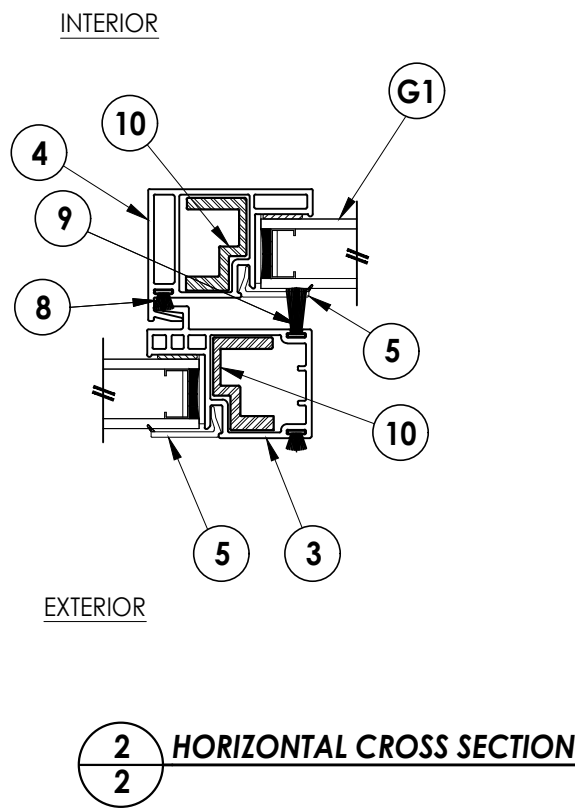
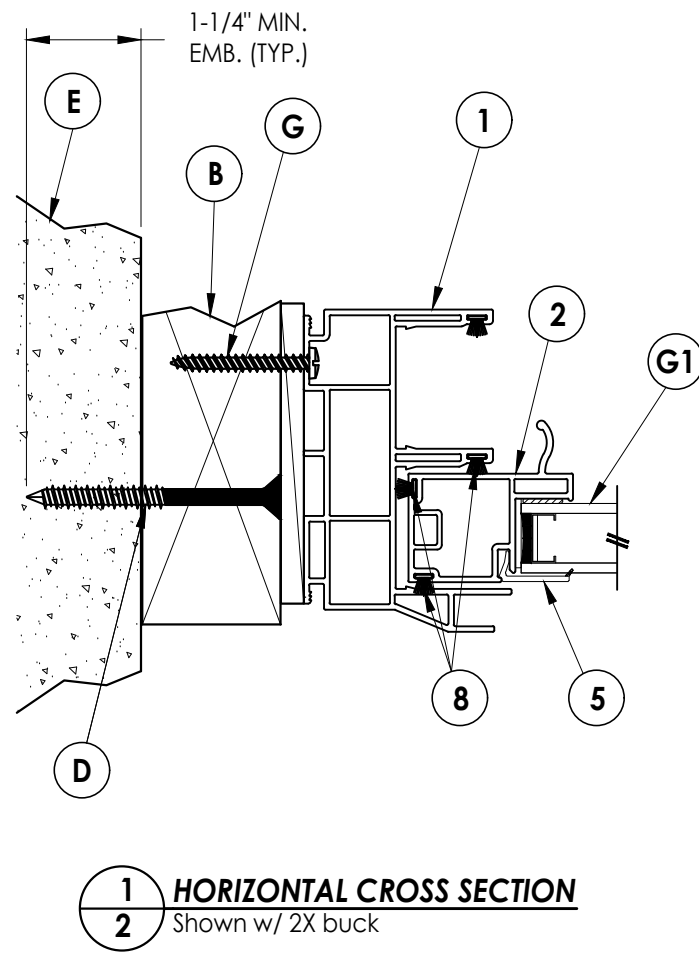
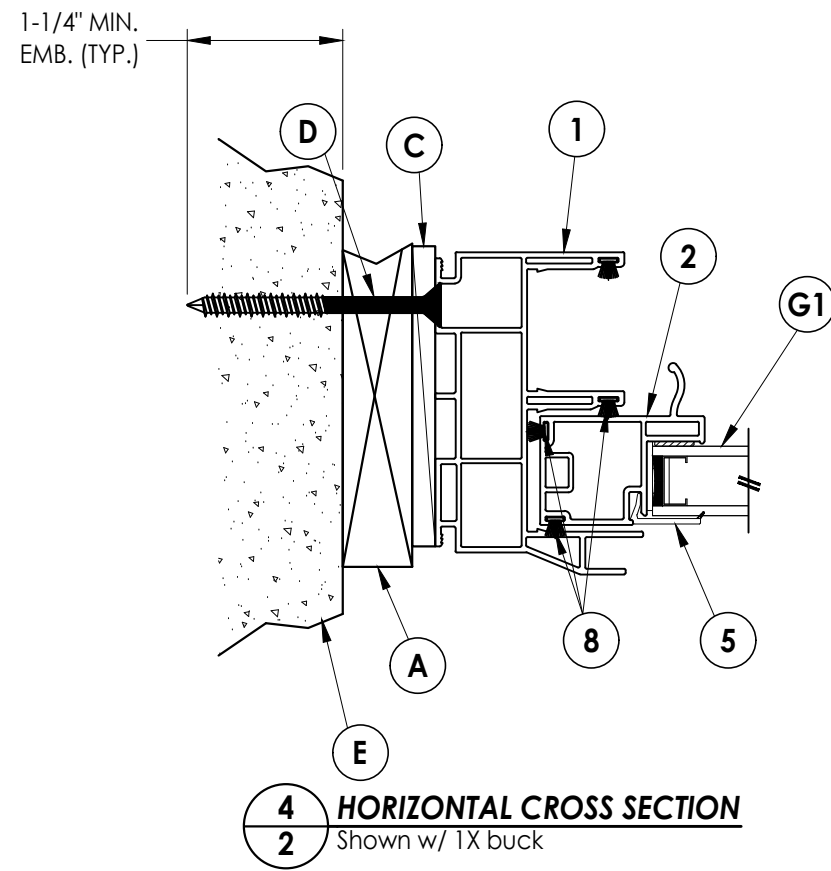
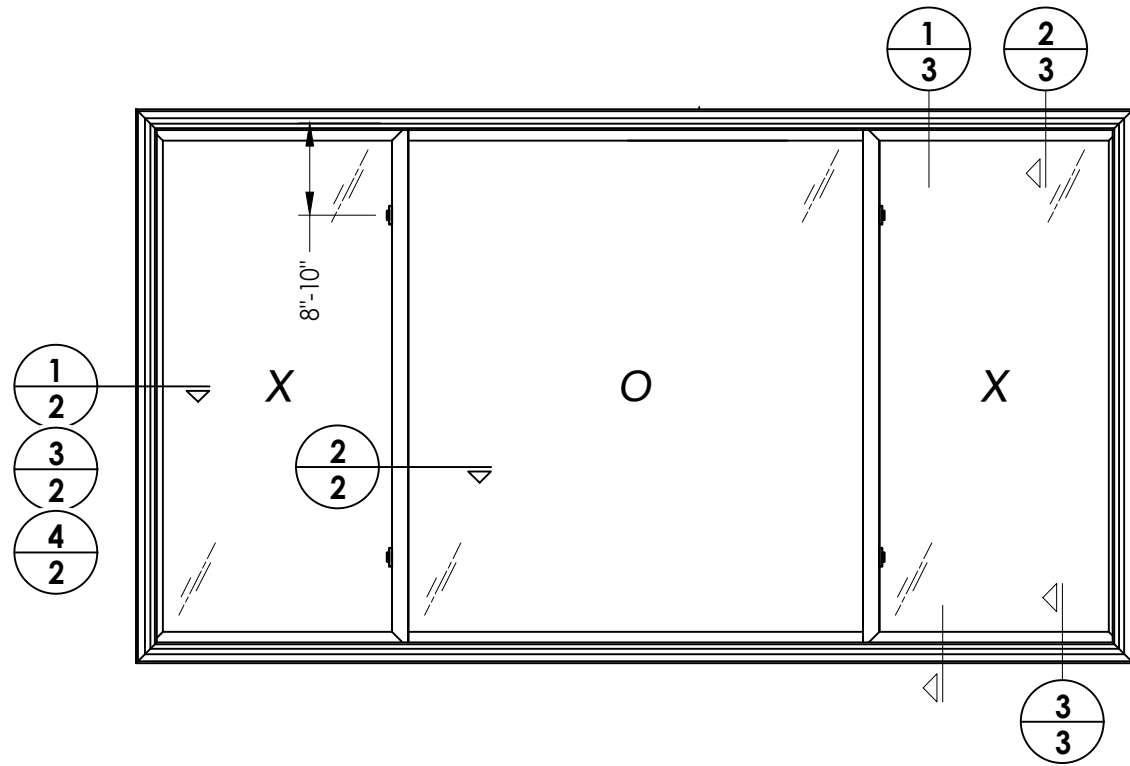

Documents Prepared By:
Lyndon F. Schmidt
P.E. No. 43409

RW BUILDING CONSULTANTS, INC.
P.O. Box 230, Valrico, FL 33595
Phone No.: 813.659.9197
FBPE Registry No. 9813

PRODUCT: 5400/5400S SERIES
1/4-1/2-1/4

PART OR ASSEMBLY:
HORIZONTAL CROSS SECTIONS

NO.	DATE	BY
4	7/06/23	FBC
3	7/06/20	FBC
2	6/01/17	FBC
1	1/28/15	FBC

DATE: 10/4/13
SCALE: N.T.S.
DWG. BY: JK
CHK. BY: LFS
DRAWING NO.: FL-16092.19
SHEET 2 OF 6

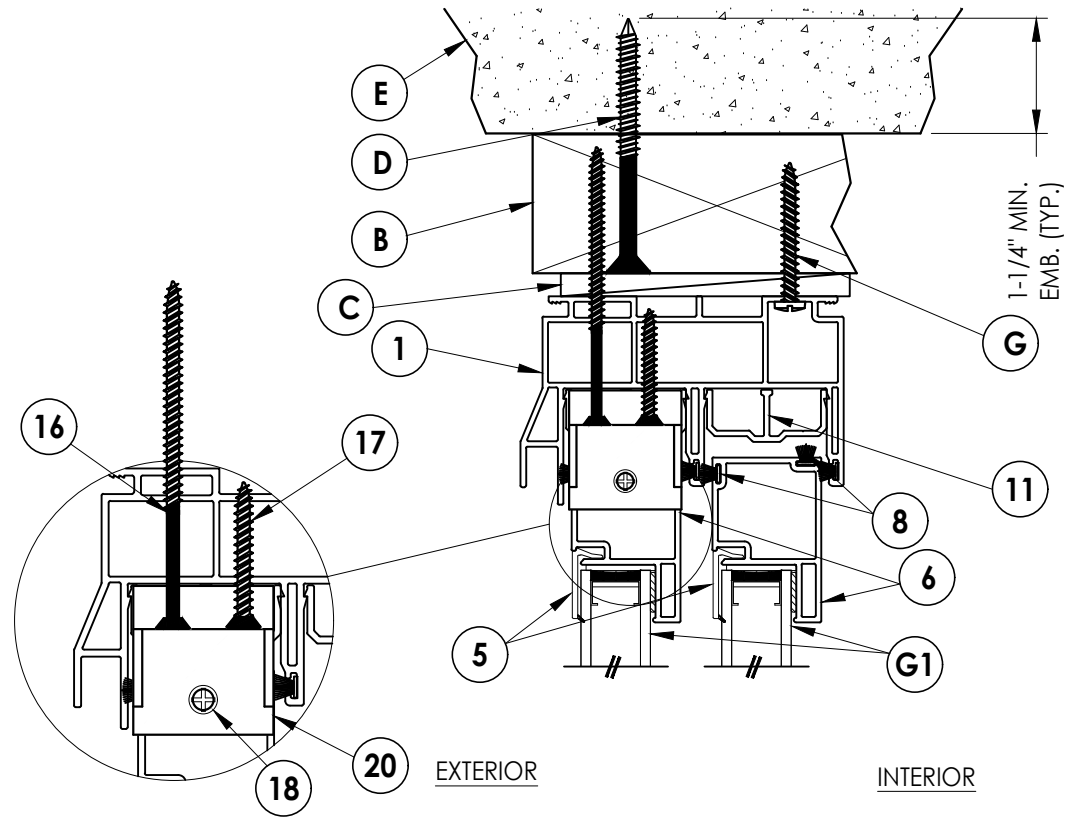

1 VERTICAL CROSS SECTION
3 Shown w/ 2X buck

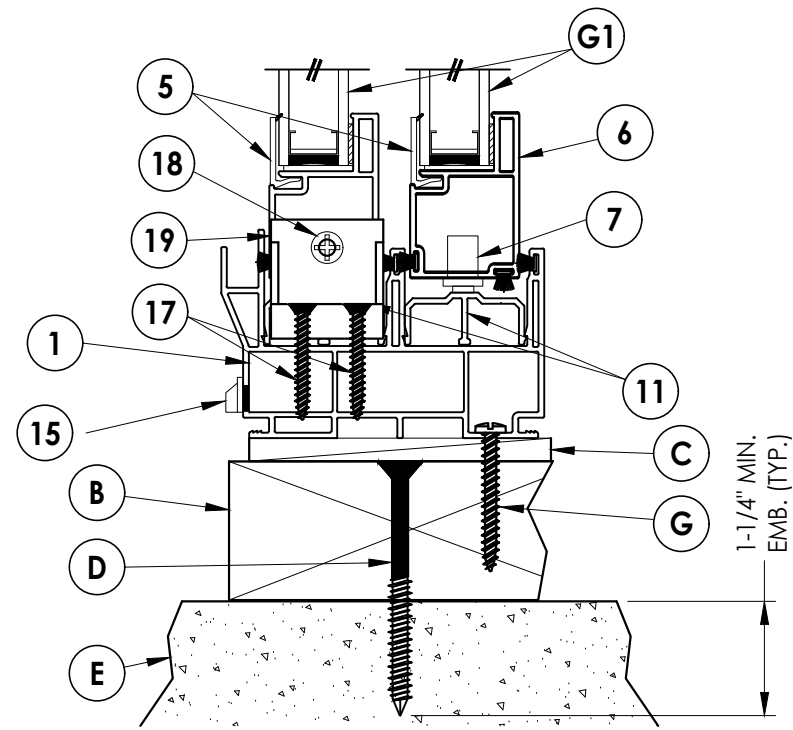

1 VERTICAL CROSS SECTION
3 Shown w/ 2X buck

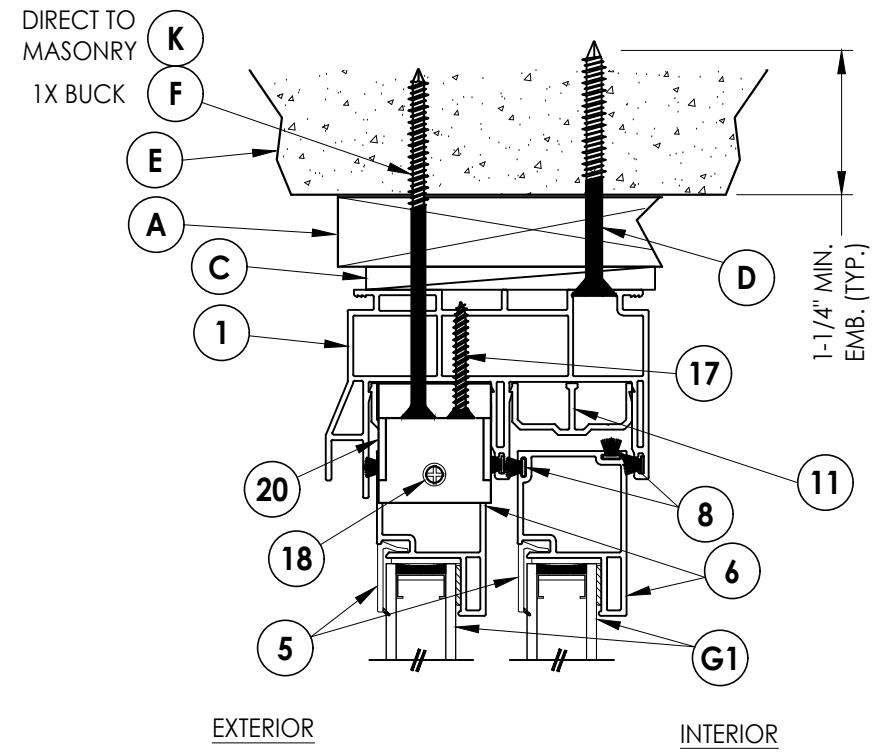

2 VERTICAL CROSS SECTION
3 Shown w/ 1X buck

EXTERIOR INTERIOR

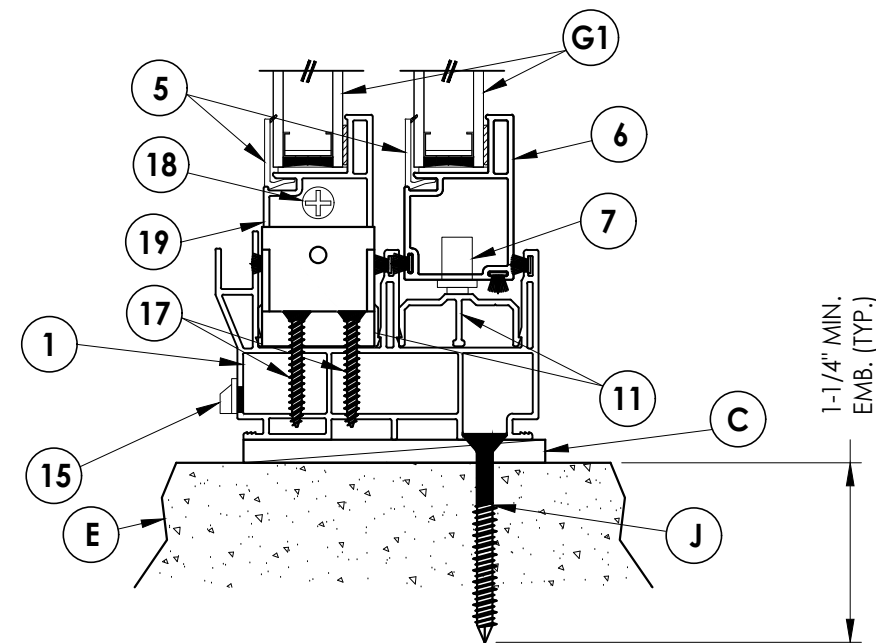

3 VERTICAL CROSS SECTION
3 Shown direct to masonry

Documents Prepared By:
 Lyndon F. Schmidt
 P.E. No. 43409

RW BUILDING CONSULTANTS, INC.
 P.O. Box 230, Vairico, FL 33595
 Phone No.: 813.659.9197
 FBPE Registry No. 9813

PRODUCT: 5400/5400S SERIES
 1/4-1/2-1/4
 PART OR ASSEMBLY: VERTICAL CROSS SECTIONS

NO.	DATE	BY
4	7/06/23	UPDATE TO 8TH ED. (2023) FBC LFS
3	7/06/20	UPDATE TO 7TH ED. (2020) FBC LFS
2	6/01/17	UPDATE TO 6TH ED. (2017) FBC LFS
1	1/28/15	UPDATE TO 5TH ED. (2014) FBC JK

DATE: 10/4/13
 SCALE: N.T.S.
 DWG. BY: JK
 CHK. BY: LFS
 DRAWING NO.: FL-16092.19
 SHEET 3 OF 6

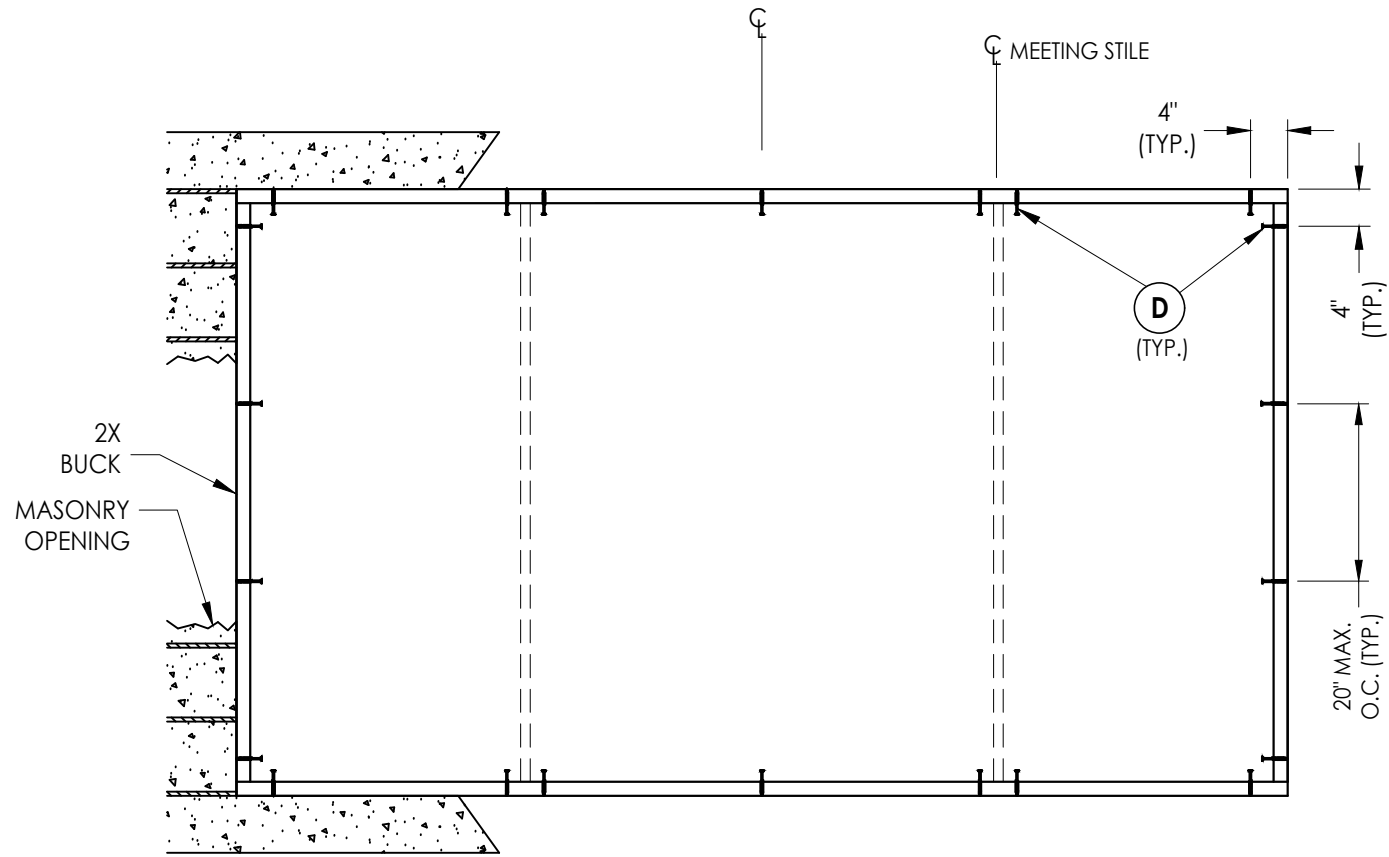

BUCK ANCHORING

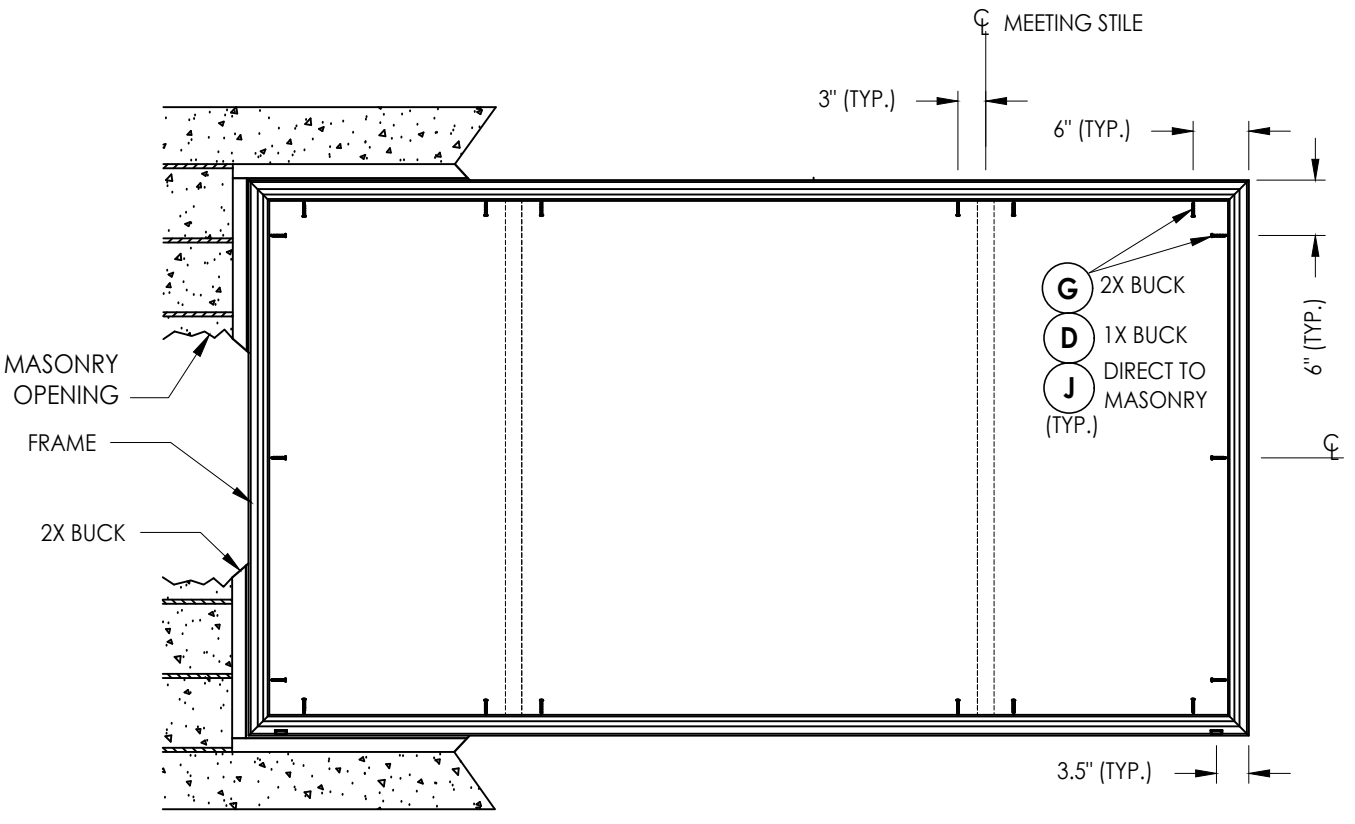

FRAME ANCHORING

CONCRETE ANCHOR NOTES:

- Concrete anchor locations at the corners may be adjusted to maintain the min. edge distance to mortar joints.
- Concrete anchor locations noted as "MAX. ON CENTER" must be adjusted to maintain the min. edge distance to mortar joints, additional concrete anchors may be required to ensure the "MAX. ON CENTER" dimension are not exceeded.
- Concrete anchor table:

ANCHOR TYPE	ANCHOR SIZE	MIN. EMBEDMENT	MIN. CLEARANCE TO MASONRY EDGE	MIN. CLEARANCE TO ADJACENT ANCHOR
ITW TAPCON®	1/4"	1-1/4"	2"	4"
DeWALT ULTRACON®	1/4"	1-1/4"	1"	4"

WOOD SCREW INSTALLATION NOTES:

- Maintain a minimum 5/8" edge distance, 1" end distance, & 1" o.c. spacing of wood screws to prevent the splitting of wood.

Documents Prepared By:
Lyndon F. Schmidt
P.E. No. 43409

RW BUILDING CONSULTANTS, INC.
P.O. Box 230, Vairico, FL 33595
Phone No.: 813.659.9197
FBPE Registry No. 9813

PRODUCT:
5400/5400S SERIES
1/4-1/2-1/4

PART OR ASSEMBLY:
BUCK AND
FRAME ANCHORING

NO.	DATE	REVISIONS
4	7/06/23	UPDATE TO 8TH ED. (2023) FBC LFS
3	7/06/20	UPDATE TO 7TH ED. (2020) FBC LFS
2	6/01/17	UPDATE TO 6TH ED. (2017) FBC LFS
1	1/28/15	UPDATE TO 5TH ED. (2014) FBC JK

DATE: 10/4/13
SCALE: N.T.S.
DWG. BY: JK
CHK. BY: LFS
DRAWING NO.: FL-16092.19
SHEET 4 OF 6

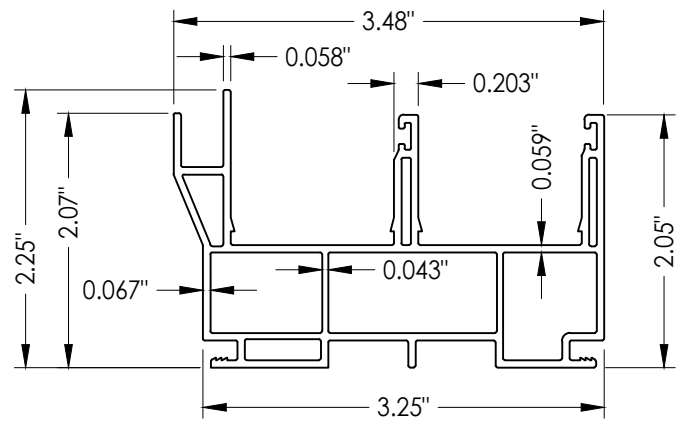

1 **FRAME**

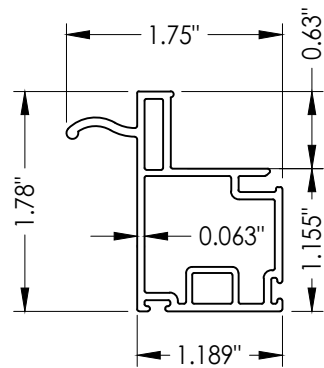

2 **SLIDER PULL STILE**

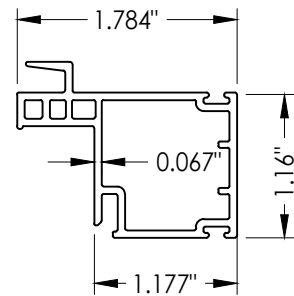

3 **LOCK STILE**

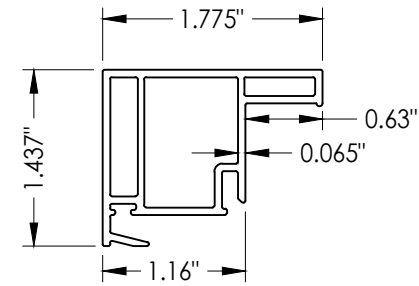

4 **KEEPER STILE**

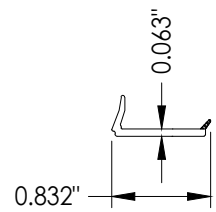

5 **GLAZING BEAD**

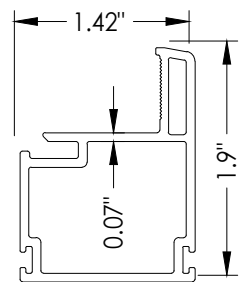

6 **SLIDER COMMON RAIL**

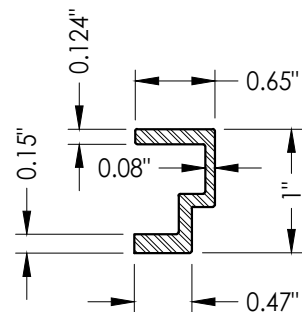

10 **REINFORCEMENT**

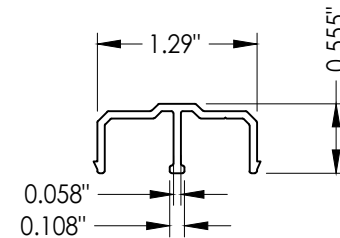

11 **SILL TRACK**

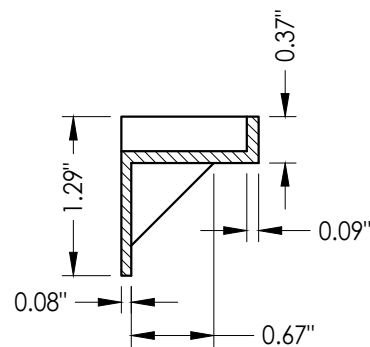

19 **LOWER FLANKER STOP**

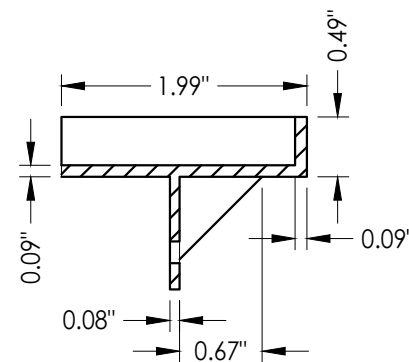
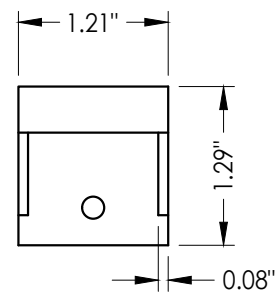

20 **UPPER FLANKER STOP**

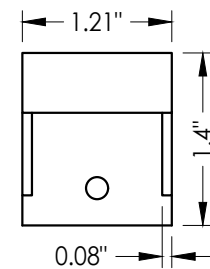

Documents Prepared By:
Lyndon F. Schmidt
P.E. No. 43409

RW BUILDING CONSULTANTS, INC.
P.O. Box 230, Vairico, FL 33595
Phone No.: 813.659.9197
FBPE Registry No. 9813

PRODUCT:
5400/5400S SERIES
1/4-1/2-1/4

PART OR ASSEMBLY:
COMPONENTS

NO.	DATE	BY
4	7/06/23	LFS
3	7/06/20	LFS
2	6/01/17	LFS
1	1/28/15	JK

DATE: 10/4/13

SCALE: N.T.S.

DWG. BY: JK

CHK. BY: LFS

DRAWING NO.:

FL-16092.19

SHEET 5 OF 6

BILL OF MATERIALS

ITEM #	DESCRIPTION	PART#	MATERIAL
A	1X BUCK SG >= 0.55	-	WOOD
B	2X BUCK SG >= 0.55	-	WOOD
C	1/4" MAX. SHIM SPACE	-	-
D	1/4" X 2-3/4" PFH DeWALT OR ITW CONCRETE SCREW	-	STEEL
E	MASONRY - 3,000 PSI MIN. CONCRETE CONFORMING TO ACI 301 OR HOLLOW BLOCK CONFORMING TO ASTM C90	-	CONCRETE
F	1/4" X 3-3/4" PFH DeWALT OR ITW CONCRETE SCREW	-	STEEL
G	#10 X 1-3/4" PPH WOOD SCREW (1-3/16" MIN. EMBEDMENT)	-	STEEL
J	1/4" X 2-1/4" PFH DeWALT OR ITW CONCRETE SCREW	-	STEEL
K	1/4" X 3-1/4" PFH DeWALT OR ITW CONCRETE SCREW	-	STEEL
1	FRAME*	DS5401A	PVC
2	SLIDER PULL STILE*	SE4647	PVC
3	LOCK STILE*	SE4646	PVC
4	KEEPER STILE*	SE4644	PVC
5	GLAZING BEAD*	22841	PVC
6	SLIDER COMMON RAIL*	SE4645	PVC
7	BALL BEARING ROLLER	-	-
8	WEATHERSTRIP (0.230")	-	-
9	WEATHERSTRIP (0.380")	-	-
10	REINFORCEMENT (6063-T6 ALUM)	-	ALUM
11	SILL TRACK*	V777	PVC
15	WEEPHOLE CAP*	WEEP-1288	PVC
16	#8 X 3" PFH SMS (1-5/16" MIN. EMBEDMENT)	-	STEEL
17	#8 X 1-1/4" PFH SMS	-	ALUM
18	#8 X 3/4" PFH WOOD SCREW	-	STEEL
19	LOWER FLANKER STOP	2991C	NYLON
20	UPPER FLANKER STOP	2991B	NYLON

* THE APPROVED WHITE RIGID PVC EXTERIOR EXTRUSIONS FOR WINDOWS ARE TO BE PRODUCED BY EXTRUDERS LICENSEES IN "AAMA CERTIFICATION PROGRAMS FOR RIGID PVC EXTRUSIONS".

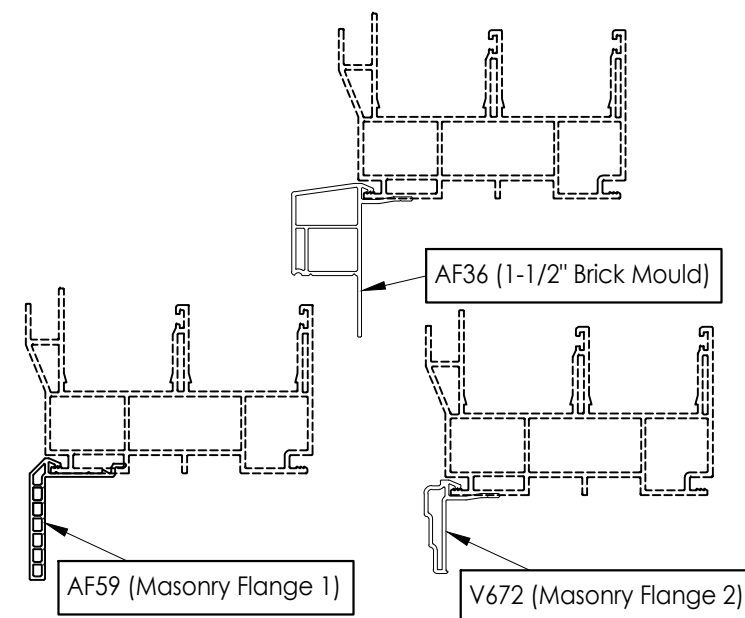

OPTIONAL COSMETIC FLANGES

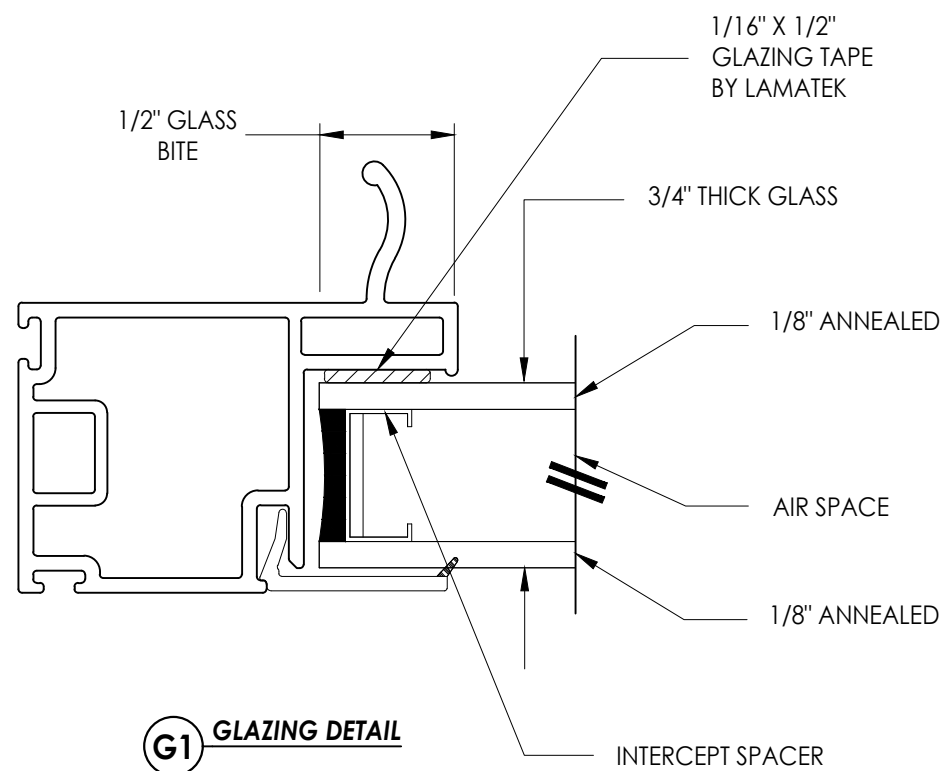

G1 GLAZING DETAIL

Documents Prepared By:
Lyndon F. Schmidt
P.E. No. 43409

RW BUILDING CONSULTANTS, INC.
P.O. Box 230, Valrico, FL 33595
Phone No.: 813.659.9197
FBPE Registry No. 9813

PRODUCT: 5400/5400S SERIES
1/4-1/2-1/4

PART OR ASSEMBLY:
BILL OF MATERIALS
& GLAZING DETAIL

NO.	DATE	REVISIONS
4	7/06/23	UPDATE TO 8TH ED. (2023) FBC LFS
3	7/06/20	UPDATE TO 7TH ED. (2020) FBC LFS
2	6/01/17	UPDATE TO 6TH ED. (2017) FBC LFS
1	1/28/15	UPDATE TO 5TH ED. (2014) FBC JK
		BY

DATE: 10/4/13

SCALE: N.T.S.

DWG. BY: JK

CHK. BY: LFS

DRAWING NO.:
FL-16092.19

SHEET 6 OF 6